

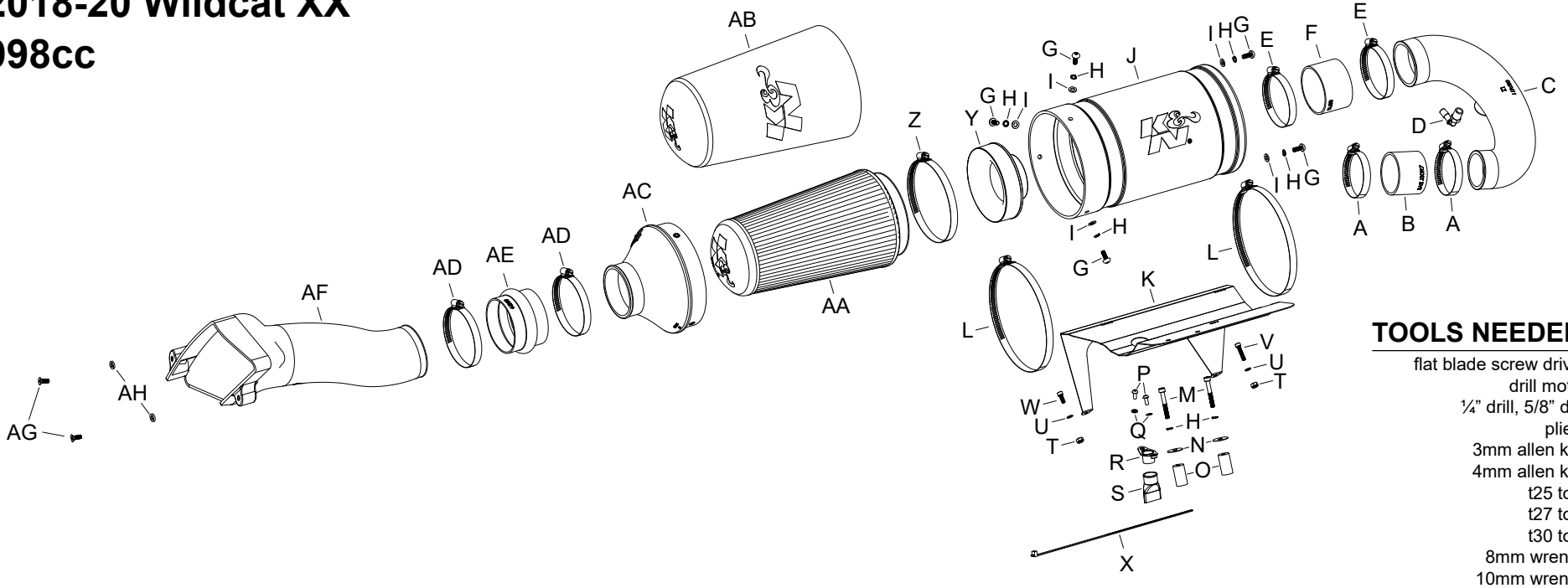

INTAKE SYSTEMS FOR VEHICLES LISTED ARE 50 STATE LEGAL. SEE KNFILTERS.COM FOR CARB STATUS ON EACH PART FOR A SPECIFIC VEHICLE.

INSTALLATION INSTRUCTIONS

57-1144
TEXTRON
2018-20 Wildcat XX
998cc



- TOOLS NEEDED:**
- flat blade screw driver
 - drill motor
 - 1/4" drill, 5/8" drill
 - pliers
 - 3mm allen key
 - 4mm allen key
 - t25 torx
 - t27 torx
 - t30 torx
 - 8mm wrench
 - 10mm wrench

PARTS LIST:

Description	Qty.	Part #	Description	Qty.	Part #	Description	Qty.	Part #
A HOSE CLAMP; #40	2	08554	L HOSE CLAMP; #116	2	08647	W BOLT	1	22265
B HOSE, SILICONE 2.50X2"	1	5-252	M BOLT	2	22266	X CABLE TIES; 11" BLACK	1	21590
C INTAKE TUBE	1	087411	N WASHER; 1"D X 1/4 HOLE	2	08160	Y ADAPTER; FILTER, 3.0"OD	1	21569
D FITTING; VENT 1/4NPT, 90DEG.	1	08110FK	O SPACER; 1-1/4" ALUMINUM	2	KITSPACER03	Z HOSE CLAMP #80	1	08694
E HOSE CLAMP; #48	2	08601	P BOLT; M5 X .8 X 12MM, SS	2	07734	AA FILTER CHARGER	1	RU-5065XD
F HOSE; 3"ID X 2"L REINFORCED	1	08711	Q WASHER; 5MM INTERNAL CUT	2	07724	AB EXTREME DUTY PRECLEANER	1	25-5168
G BOLT; M6 X 1.00 X 16MM, SS	5	07730	R PLATE; VENT, TK/PC	1	073280	AC LID; LR, XLHDPE	1	087345A
H WASHER; M6 SPLIT LOCK ZINC	7	1-3025	S HOSE; DUCK BILL, EPDM	1	08666	AD HOSE CLAMP; #56	2	08620
I WASHER; 6MM FLAT, SS	5	08269	T NUT; M5 X 0.8", NYLOCK, SS	2	07507	AE HOSE; HUMP 3.5"ID X 2.5"L	1	08699
J CANISTER; LQ, XLHDPE	1	087344A	U WASHER; 5MM FLAT, SS	2	08212	AF DUCT; MA, XLHDPE	1	087412
K BRACKET; CANISTER, STEEL	1	010089	V BOLT; M5 X .8 X 14MM, OX	1	07773	AG BOLT; 6MM; X 16MM, SS.B, FHA	2	22256
						AH WASHER	2	08180

If you need any assistance please call 1-800-858-3333 to speak with a representative in our Customer Service Center before returning the product.

NOTE: FAILURE TO FOLLOW INSTALLATION INSTRUCTIONS AND NOT USING THE PROVIDED HARDWARE MAY DAMAGE THE INTAKE TUBE, THROTTLE BODY AND ENGINE.

TO START:

1. Turn off the ignition and disconnect the negative battery cable.
NOTE: Disconnecting the negative battery cable erases pre-programmed electronic memories. Write down all memory settings before disconnecting the negative battery cable. Some radios will require an anti-theft code to be entered after the battery is reconnected. The anti-theft code is typically supplied with your owner's manual. In the event your vehicles anti-theft code cannot be recovered, contact an authorized dealership to obtain your vehicles anti-theft code.



2. Remove the four bolts that secure the cargo tub and then remove the tub from the vehicle.



3. Pull out the yellow air filter latch, rotate the air filter housing counter clockwise to unlock and then remove the cover and factory air filter from the vehicle.



4. Loosen the hose clamp that secures the clutch cover fresh air intake hose to the inlet.



5. Pull the clutch fresh air intake hose down and secure it so that access is achieved for the intake system hose clamps.



6. Release the spring clamp that secures the breather hose and then disconnect the breather hose.



7. Loosen the hose clamp that secures the intake tube to the air filter housing and then disconnect the hose from air filter housing.



8. Loosen the hose clamp that secures the intake tube to the throttle body and then disconnect the tube from the throttle body and remove the tube from the vehicle.

NOTE: K&N Engineering, Inc., recommends that customers do not discard factory air intake.



9. Remove the two bolts that secure the air filter housing to the intake manifold using a T30 torx.
NOTE: Access to these bolts is tight.



10. Install the K&N® air filter housing lid onto the K&N® air filter housing without the K&N® air filter. Then install the housing onto the mounting bracket and secure with the provided hose clamps as shown.



11. Position the drain bracket through the opening in the bracket as shown and use a silver marker or equivalent to mark hole locations to be drilled. Two holes will be for the bolts to hold the drain plate on and the third hole will be a drain hole.



12. Drill two 1/4" id holes for the bolts and one 5/8" id hole for the drain where marked and then secure the drain bracket onto the filter housing.



13. Install the filter adapter into the K&N® air filter and secure with the provided hose clamp.



14. Install the K&N® pre-filter onto the K&N® air filter as shown.



15. Install the filter assembly into the K&N® filter housing and secure with the provided hardware.



16. Install the Filter housing end and secure with the provided hardware.



17. Install the duck bill drain onto the drain bracket and secure with the provided tie wrap.



18. Using the bolt, washer and spacers shown, position the air filter housing bracket onto the engine and secure with the bolts to the factory air filter housing mounting locations. Do not tighten the bolts at this time.

NOTE: Install the bracket using one set of hardware on the inner most bolt first and then install the second set of hardware.



19. Secure the back side of the bracket to the engine using the hardware provided. The bracket will mount to two factory tabs with holes on the side of the cylinder head near the valve cover. Tighten all of the bolts at this time.

NOTE: It may be helpful to tape the nuts to a wrench to hold the bolts under the bracket.



20. Install the vent fitting into the K&N® intake tube as shown.

NOTE: Plastic NPT fittings are easy to cross thread. Install the vent fitting "hand" tight, then turn it two complete turns with a wrench.



21. Remove the vent fitting from the factory intake tube and install it onto the fitting installed into the K&N® intake tube as shown.



22. Install the provided coupler (5-252) onto the throttle body and secure with the provided hose clamp.

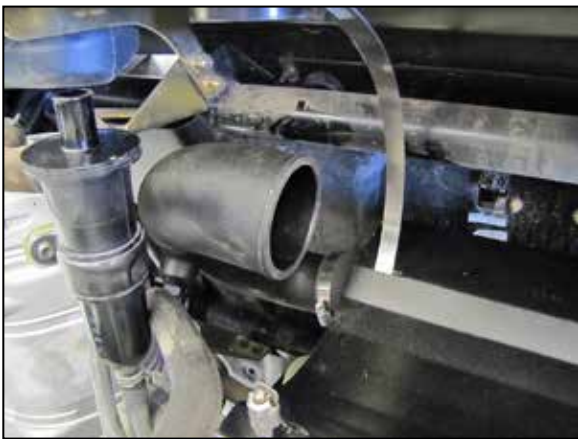

23. Install the K&N® intake tube into the coupler on the throttle body but do not completely tighten at this time.



24. Reinstall the clutch fresh air intake hose onto intake and secure with the provided hose clamp.



25. Install the provided coupler (08711) onto the K&N® intake tube and secure with the provided hose clamp.



26. Slide the K&N® air filter housing onto the bracket and position so the duck bill drain is through the bracket. Secure the air filter housing with the hose clamps.



27. Reconnect the vent hose and secure with the factory clamp.

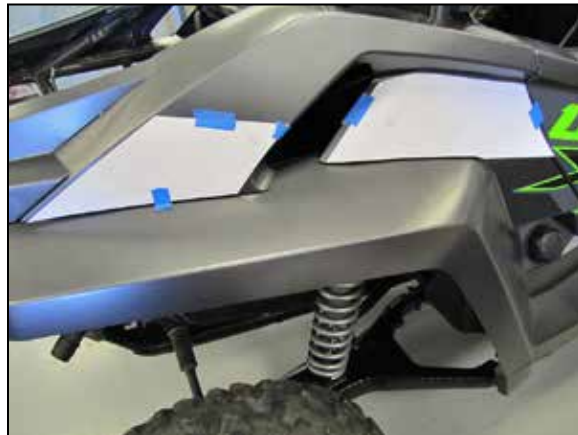

28. Cut out the two drill templates and then tape them to the side panel as shown. Drill 1/4" holes through the panel using the templates as a guide. **NOTE: Align the templates along the bottom edge of the panel.**



29. Install the provided coupler (08699) onto the Fresh air duct and then install the duct onto the air filter housing but do not completely tighten at this time.

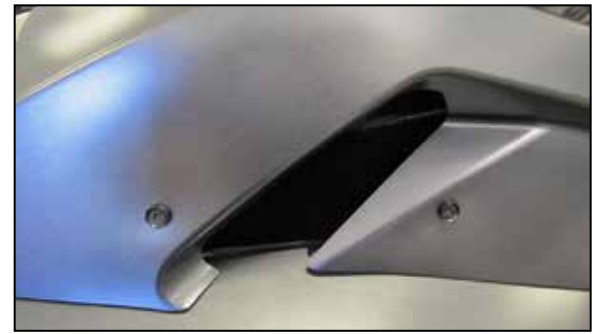

30. Secure the duct to the exterior panel using the provided hardware.



31. Tighten the hose clamps securing the filter housing to the duct.



32. Reinstall the cargo box and secure with the factory hardware.

33. Reconnect the vehicle's negative battery cable. Double check to make sure everything is tight and properly positioned before starting the vehicle.

34. The C.A.R.B. exemption sticker, (attached), must be visible under the hood so that an emissions inspector can see it when the vehicle is required to be tested for emissions. California requires testing every two years, other states may vary.

35. It will be necessary for all K&N® high flow intake systems to be checked periodically for realignment, clearance and tightening of all connections. Failure to follow the above instructions or proper maintenance may void warranty.

ROAD TESTING:

1. Start the engine with the transmission in neutral or park, and the parking brake engaged. Listen for air leaks or odd noises. For air leaks secure hoses and connections. For odd noises, find cause and repair before proceeding. This kit will function identically to the factory system except for being louder and much more responsive.

2. Test drive the vehicle. Listen for odd noises or rattles and fix as necessary.

3. If road test is fine, you can now enjoy the added power and performance from your kit.

4. K&N Engineering, Inc., requires cleaning the intake system's air filter element every 100,000 miles. When used in dusty or off-road environments, our filters will require cleaning more often. We recommend that you visually inspect your filter once every 25,000 miles to determine if the screen is still visible. When the screen is no longer visible some place on the filter element, it is time to clean it. To clean and re-oil, purchase our filter Recharger® service kit, part number 99-5050 or 99-5000 and follow the easy instructions.

INTAKE SYSTEMS FOR VEHICLES LISTED ARE 50 STATE LEGAL. SEE KNFILTERS.COM FOR CARB STATUS ON EACH PART FOR A SPECIFIC VEHICLE.

DRILL TEMPLATE

ALIGN BOTTOM EDGE

ALIGN BOTTOM EDGE

DRILL
1/4"



DRILL TEMPLATE

DRILL TEMPLATE

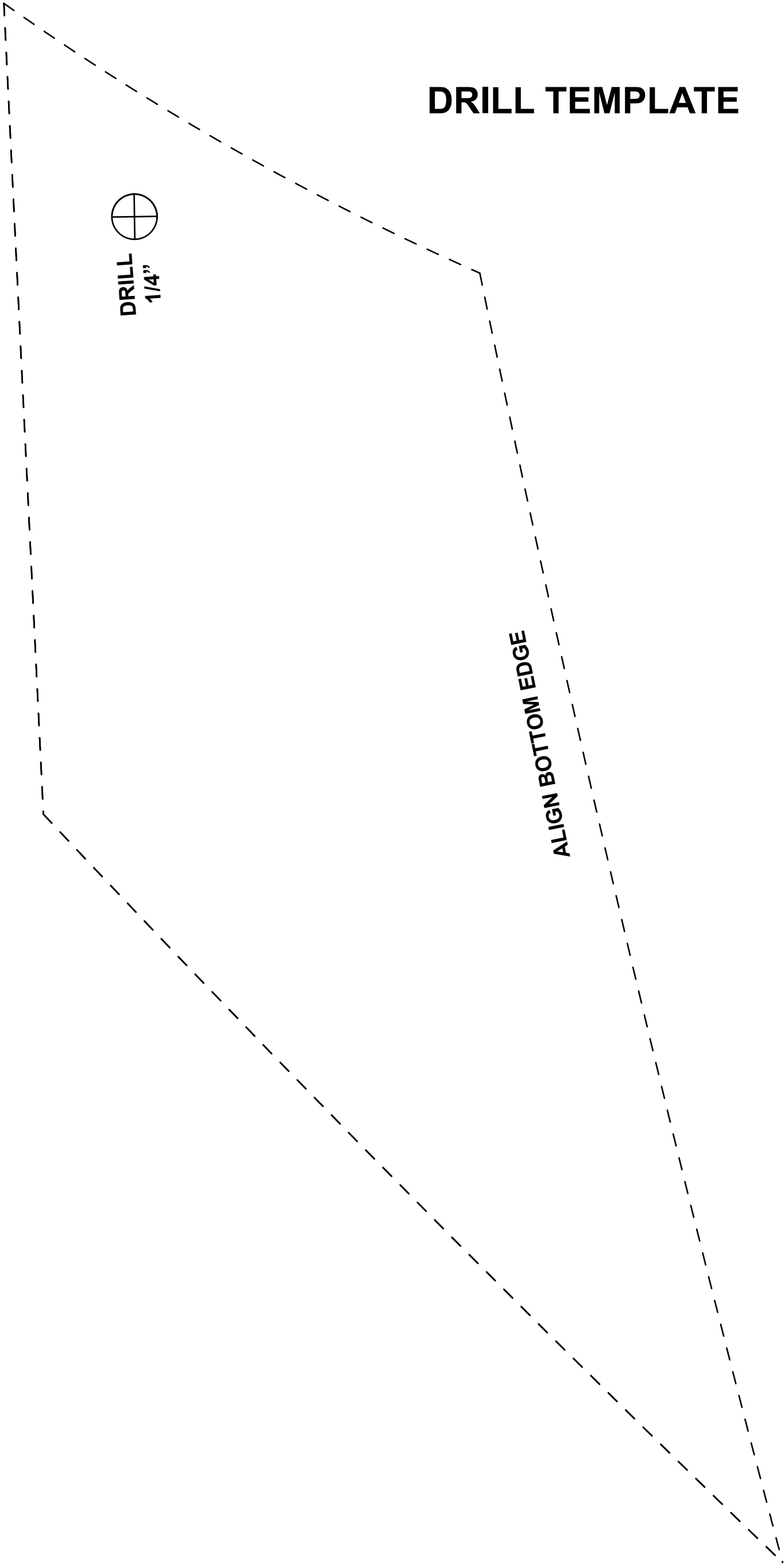

DRILL TEMPLATE